

Optimum Thickness Distribution of an Inkjet-Printed Resonant Line Antenna

#Sumin Yun , Sangwook Nam

School of Electrical Engineering and INMC, Seoul National University
1 Gwanak-ro, Gwanak-gu, Seoul, Korea, ysoom@ael.snu.ac.kr

Abstract

The optimum thickness distribution for the antenna efficiency enhancement of a resonant line antenna is proposed. Unlike a standard printed circuit board process, which removes the unwanted metal from the substrate, inkjet-printing technology is an additive process. By using the inkjet-printing technology, the thickness of a line can be controlled. The calculated loss along the antenna showed that the power loss along the line antenna is minimum when thickness and current has a same distribution. For the demonstration, the continuous sinusoidal distribution is replaced by the 5 - layered dipole antenna. The simulated results show that the proposed distribution has a 2 %p higher antenna efficiency and 0.12 dBi higher gain compared to the those of the flat dipole antenna with a same volume. The proposed thickness distribution can be used to enhance the antenna efficiency of a resonant line antenna with the known current distribution.

Keywords : inkjet printed antenna, thickness control, antenna efficiency enhancement.

1. Introduction

Inkjet printed antenna has many advantages over a conventionally etched antenna. One of its advantages is a low-cost characteristic. Compared to the conventional etching process, which removes unwanted metals from a substrate, inkjet printing is an additive process. Inkjet printer jets the conducting ink to the area where designed antenna should be placed. It uses just an amount of ink which is needed for the antenna fabrication. This additive process enables the thickness control of a line antenna.

Several heuristic techniques considering the current distribution of a dipole antenna are proposed to enhance the antenna efficiency [1], [2]. In [1], the bow-tie dipole antenna with a variable ink layer thickness is proposed [1]. A thick layer is used at the center of the dipole and a thin layer is used at the rest part of the dipole. Although the radiation efficiency is decreased, an amount of ink used in antenna is significantly decreased. In [2], a linearly-tapered dipole antenna is proposed. With an identical volume of conducting material, the tapered antennas can achieve better radiation performance than non-tapered ones on antenna gains and radiation efficiencies.

In this paper, the optimum thickness of a resonant line antenna is presented using the loss calculations along the dipole antenna. When thickness has a same distribution with a current distribution along the antenna, the loss is minimized. For the demonstration, 5-layered dipole is presented and compared with a flat dipole antenna with a same volume using the simulation. Length of each layer is determined considering the sinusoidal distribution. The simulation showed that 5-layered dipole has the 2 %p higher antenna efficiency than those of a flat dipole antenna. The antenna efficiency enhancement can be achieved using the proposed distribution in the given antenna volume.

2. Optimum thickness distribution of a resonant line antenna

To obtained the optimum thickness distribution of a resonant line antenna, the loss on the resistive line is calculated. Using the calculated results, the optimum thickness distribution of a dipole antenna is obtained under the given current distribution along the antenna. The thickness

control along the line antenna may change the current distribution of the line antenna slightly. For the simple calculation, it is assumed that the thickness control does not changes the original current distribution of a line antenna.

2.1 Power losses on the resistive line

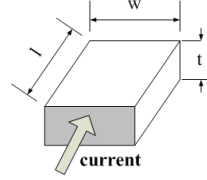

Figure 1: Resistive line.

In the given resistive line, the power loss can be easily calculated using the equations which is presented in [3].

$$P = \frac{I_{rms}^2 l \rho}{4w\delta} (1 - e^{-t/\delta})(1 - e^{-t/2\delta})^{-2}$$

$$\approx \frac{I_{rms}^2 l \rho}{wt} \quad (\text{when } t \ll \delta) \quad (1)$$

where I is a current which flows through the line and ρ , δ is a resistivity and skin depth of a resistive material. When $t \ll \delta$, the loss on the line is inverse proportional to the thickness of a resistive line. By controlling the thickness of the resistive line, the power loss can be adjusted.

2.2 Calculation of the optimum thickness of the dipole antenna

As the losses on the line is inverse proportional to the thickness of the line, the optimum thickness of the printed antenna may be calculated once the current distribution is known. For the case of a conventional dipole antenna, it is usually assumed that current has a sinusoidal distribution. We used same assumption in our calculation as shown in fig. 2.

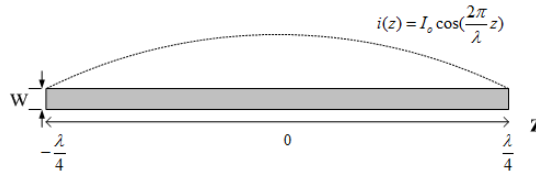

Figure 2: Assumed current distribution of dipole antenna.

Considering the sinusoidal current distribution, the thickness also need to be the sinusoidal distribution along the antenna. We assumed thickness along the antenna as

$$t(d, z) = \frac{1}{v_0(d)} \cos^d \left(\frac{2\pi}{\lambda} z \right) \quad (2)$$

$$v_0(d) = \int_{-\lambda/4}^{\lambda/4} t_0 \cos^d \left(\frac{2\pi}{\lambda} z \right) dz \quad (3)$$

with a unknown order d . $v_0(d)$ is a cross sectional area of the dipole. For the fair comparison, the antenna volume should be fixed in each unknown order d . The equal volume can be achieved by dividing the each thickness distribution by its cross sectional area. The losses along the dipole antenna can be calculated using (1), (2), (3).

$$\begin{aligned}
P_{loss}(d) &= \int_{-\lambda/4}^{\lambda/4} \frac{\rho}{w} \frac{i(z)^2}{t(z)} dz \\
&= \frac{\rho I_0^2}{wt_0} \int_0^{\lambda/4} \left(\cos\left(\frac{2\pi}{\lambda}z\right)\right)^{2-d} dz \cdot \int_{-\lambda/4}^{\lambda/4} t_0 \cos\left(\frac{2\pi}{\lambda}z\right) dz
\end{aligned} \tag{4}$$

The calculated losses of a dipole antenna is normalized to the value when $d = 0$, and plotted in fig. 3. It is shown that the losses on a dipole is minimum when the $d = 1$. The first order sinusoidal distribution is the optimum thickness distribution of a dipole antenna. This result can be expanded to any type of a resonant line antenna. Any current distributions on a resonant line antenna can be expressed by the sum of the fundamental and its harmonic currents. The minimum power loss is achieved when the thickness and the current has a same distribution along the line antenna.

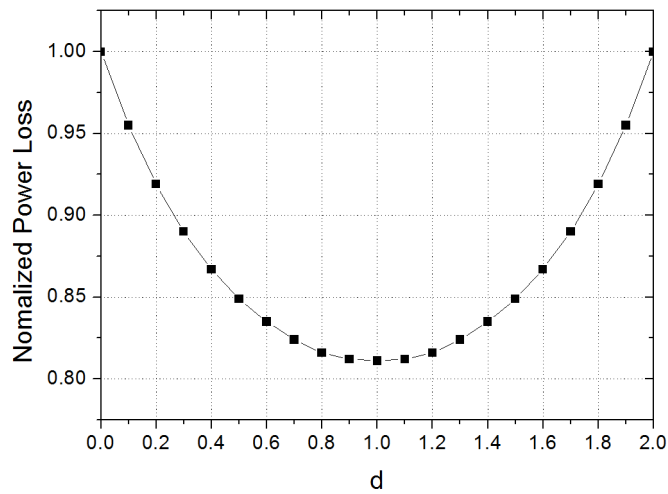

Figure 3: Normalized power loss at different order d .

3. Antenna Design

The demonstration of the proposed thickness distribution is conducted through the simulation. The proposed thickness distribution needs a continuous thickness change along the antenna. In the inkjet-printing process, however, it is impossible to fabricate the continuous thickness distribution. Hence, the sinusoidal distribution is approximated to the 5 - layered dipole with a 100 nm thickness per each layer. The length of each layer are determined by the values of the sinusoidal distribution. Values of each layer are shown in Fig. 4. The conductive material with conductivity 2.63×10^6 S/m is used. The operating frequency is set to 1 GHz. The simulation is conducted using CST microwave studio.

The antenna efficiency and the gain of proposed antenna are described in Table 1. They are compared to those of a conventional dipole antennas. The proposed antenna has 2 %p higher antenna efficiency compared to the conventional flat dipole antenna with a same volume. By using the proposed thickness distribution, the antenna efficiency and the antenna gain are enhanced. The proposed distribution also can be used to reduce the ink use along a line antenna. The ink use reduction causes inevitable antenna efficiency drop. By using the proposed distribution, however, the losses on the antenna can be reduced. Compared to the flat dipole antenna which has a 500 nm height, the proposed antenna has reduced 28.3 % volume only reducing the 6.2% antenna efficiency.

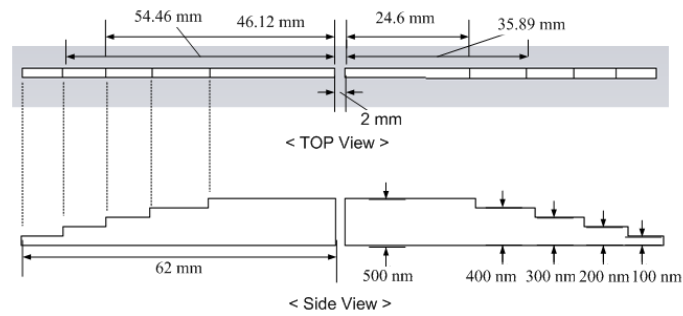

Figure 4: Antenna geometry.

Table 1: Antenna Comparison

	Volume (mm ³)	Thickness	Ant. eff (%)	Gain (dBi)
Flat antenna	0.123	500 nm	61.23	0.59
Proposed antenna	0.0882	100 nm / step	55.03	0.25
Conventional antenna	0.0882	361 nm	53.01	0.13

4. Conclusion

The optimum thickness distribution for a resonant line antenna is proposed and demonstrated. When thickness and current has a same distribution along an antenna, the power loss is minimized. The simulated results showed that the proposed distribution has 2 %p higher antenna efficiency and 0.12 dBi higher gain compared to the those of the flat dipole antenna. It is a simple method for enhancing the antenna efficiency of a resonant line antenna.

Acknowledgments

This work was supported by the IT R&D program of Ministry of Knowledge and Economy/ Korea Evaluation Institute of Industrial Technology (MKE/KEIT) [10030559, development of next generation high performance organic/nano materials and printing process technology]

References

- [1] A. J. Siden, M.K. Fein, A. Koptug, H.-E. Nilsson, "Printed antennas with variable conductive ink layer thickness," *IET Microw. Antennas propag.*, vol. 1, pp. 401–407, Apr. 2007.
- [2] B. Shao, Q. Chen, R. Liu; L. Zheng, "Linearly-tapered RFID tag antenna with 40% material reduction for ultra-low-cost applications," *RFID (RFID)*, 2011 *IEEE International Conference on* , vol., no., pp.45-49, 12-14 April 2011
- [3] S.L. Merilampi, T. Bjorninen, A. Vuorimaki, L. Ukkonen, P. Ruuskanen, L. Sydanheimo, "The Effect of Conductive Ink Layer Thickness on the Functioning of Printed UHF RFID Antennas." *IEEE Proceeding*. Vol. 98, pp. 1610–1619, Sept. 2010.